



eBook

# Optimize your cloud business with the right cloud management platform

The CloudCheckr difference





# Table of contents

**03** Is your cloud optimized?

**04** Meet CloudCheckr

**05** What makes us different

**07** How we enable differentiation  
and growth for MSPs

**11** What we value

**12** Take the next step



# Is your cloud optimized?

Cloud computing makes it simpler to provision and scale resources, but as public cloud platforms become more complex, so does managing them.

That is why selecting the right cloud management platform is critical to getting the visibility and intelligence you need to control costs, manage data privacy and security, and ensure compliance.

But with a marketplace full of cloud management providers, how do you select the right one for your organization and needs?

We invite you to look at the leading cloud management platform from CloudCheckr, now part of Spot by NetApp, which offers **multi-cloud cost optimization, cost allocation, security, and compliance management — in one single platform**. Learn why organizations typically favor us over alternatives.

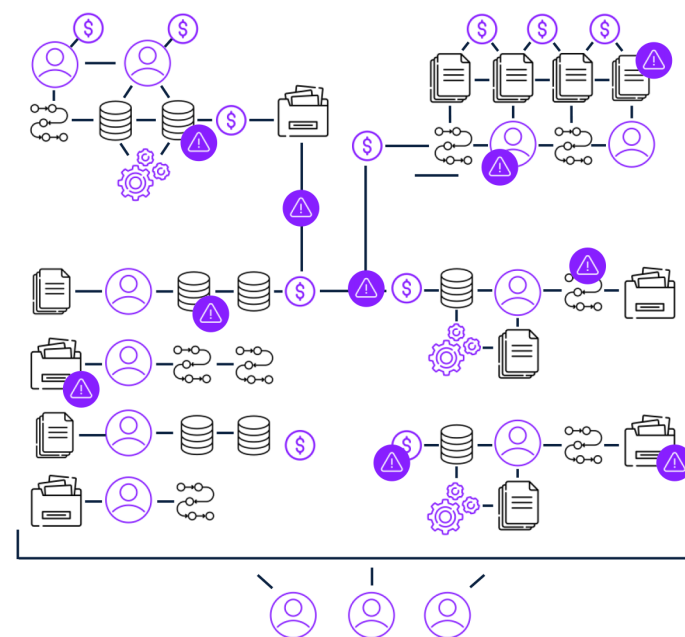

# Meet CloudCheckr

## The leading solution for complex cloud management

Global organizations use CloudCheckr to gain control of their cloud. The CloudCheckr CMx platform proactively analyzes cloud infrastructure to provide visibility and intelligence so organizations can better manage costs, make infrastructure more secure and in compliance, and optimize resources in use.

**\$4B**

Annual spend under management

**10K+**

Loyal users

**10**

Years of CMP leadership

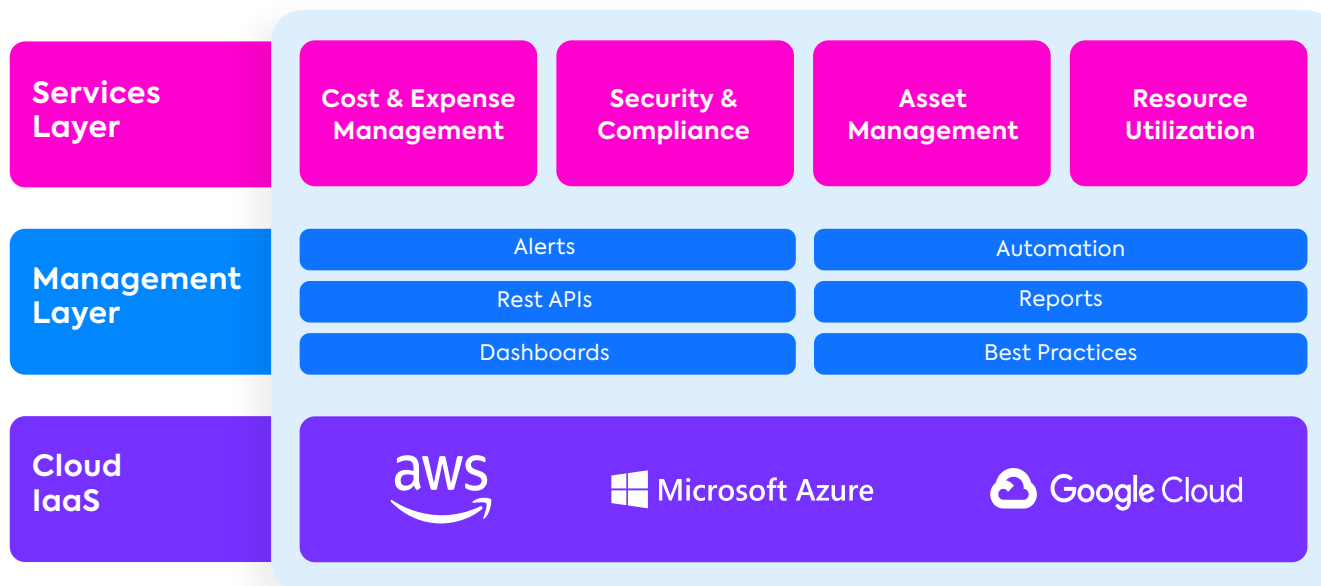

# What makes us different



## Integrated cost, security, compliance and resource management

With 600+ Best Practice Checks, CloudCheckr is the only provider to truly integrate cost optimization, availability, security, and compliance in a single platform — rather than simply bolting on separate applications such as security. That matters when any change you make to solve for one problem could help, or hurt, another aspect of your governance.

For example, security and redundancy are important for high availability, but a tool focused solely on cost optimization might recommend eliminating such redundancy, leading to downtime and even higher costs.



Up to 7 years of historical data



Easy to use dashboards and reports



Hundreds of public cloud service API connections



## Deeper data and insight

With hundreds of public cloud service API connections, CloudCheckr analyzes more data points, across more functionality, than any other agentless offering. And CloudCheckr goes back much further in time than other platforms — up to seven years of configuration changes with our SnapBack™ reporting.

With CloudCheckr organizations get the depth of insight they need to manage their cloud and the confidence to make long term decisions, such as leveraging up to six months of historical data when recommending one- or three-year reserved instance purchases. And with the industry's easiest-to-use cloud dashboards, users can get the fastest time to insight, while providing flexible options to surface data the way your organization wants, ensuring stakeholders get the info they need.



### Visibility across the enterprise

CloudCheckr provides a host of capabilities to everyone in your organization so they can view cloud data how they need, from executives to practitioners.

We provide the market's easiest-to-create dashboards to let users get and share cloud cost data and trends quickly. When you want to dig deeper, our business intelligence tooling lets you efficiently interrogate all that data we pull in to get further insights. Finally, our API-first platform allows customers to rapidly integrate CloudCheckr data and reports into complementary tools, applications and business processes.



### A true partner with white glove service and support

Service is critical to who we are, and ensuring your success is our success. White-glove, expert-driven support is included — rather than used as a mechanism to upsell or nickel-and-dime our customers. Services like Regular Recurring Cost Optimization Consultation, RI Purchasing and Management Support are included. And we continue to build capabilities for service providers to ensure they can support customers both effectively and profitably.

30%+

Cloud savings

700%

Return on investment

55%

Reduction in cloud overages





# How we enable differentiation and growth for MSPs

## What CloudCheckr does better than anyone else

The CloudCheckr cloud management platform, built to power cloud services for Amazon Web Services, Microsoft Azure and Google Cloud, enables managed service providers to differentiate themselves in a noisy cloud services marketplace.

We combine our leading platform with partner go-to-market tools and support to ensure joint success. That is why 40 percent of the 50 largest cloud service providers in the world partner with CloudCheckr to manage their public cloud environments.

## Our best-in-class platform enables MSPs to stay competitive and grow their business, so they can:

-  More effectively and comprehensively manage and optimize cloud costs, security and resources for their customers
-  Expand profits through smarter commitment-based cloud purchasing and staff expert advice – for resale or packaging with services
-  Develop unique, technology-powered service offerings to create differentiation and unlock target customer segments
-  Streamline and automate internal operations, training and reporting with a single cloud management process

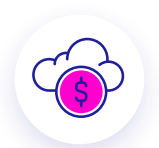

## How we help MSPs drive revenue growth & expand profit margins

MSPs leverage the CloudCheckr cloud management platform to expand services that are differentiated; better serve their customers through improved cloud ROI; and do this in a way that is profitable – both by streamlining delivery, and more importantly, by maximizing profits through more sophisticated cloud purchasing and billing for customers.

MSPs that leverage CloudCheckr grow faster than those that try to build their practice with internal tools from cloud providers. One analysis we conducted showed cloud spend grew 50% faster with CloudCheckr using a cloud management platform within the first 12-18 months. The reason is simple: customers get more ROI from their cloud investment and experience fewer challenges, so they transition faster with more confidence.







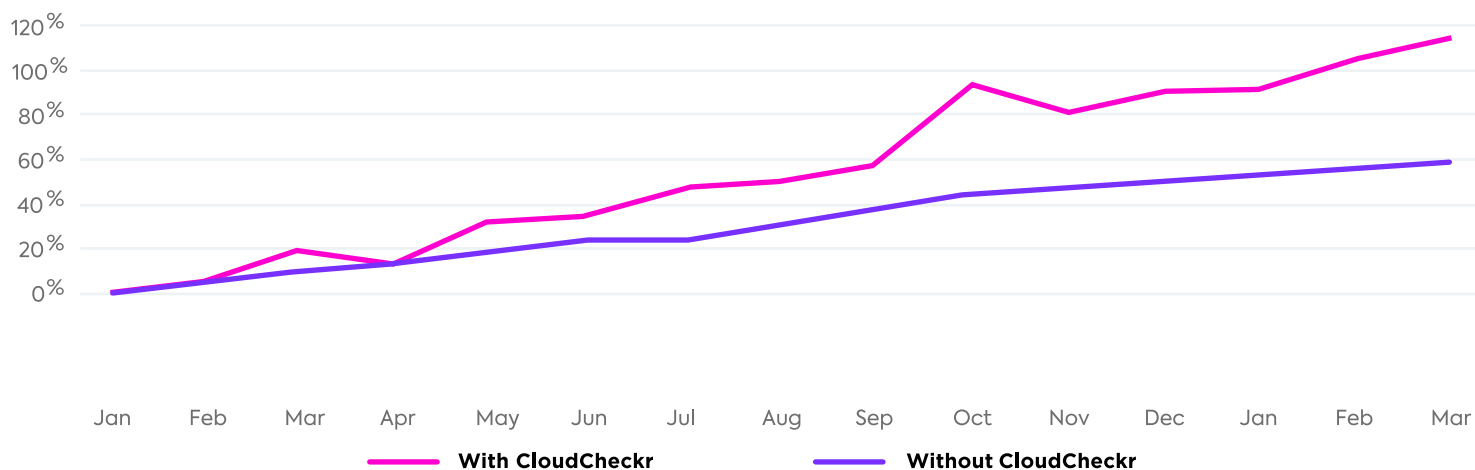

## Cloud services business grow 50% faster with CloudCheckr

### Growth in Cloud Spend



### Grow Faster

-  Provide customers with insights that build confidence
-  Accelerate cloud adoption
-  Increase customer satisfaction
-  Build MRR/ARR



Optimize your cloud business with the right cloud management platform

Additionally, many MSPs are challenged with low cloud resale margins and how to bill customers accurately. MSPs report 3-7% profit margins on cloud resale when they first engage with us. But with CloudCheckr's recommendations and billing engine, MSPs can increase that 3x-6x through a number of intelligent and automated strategies.

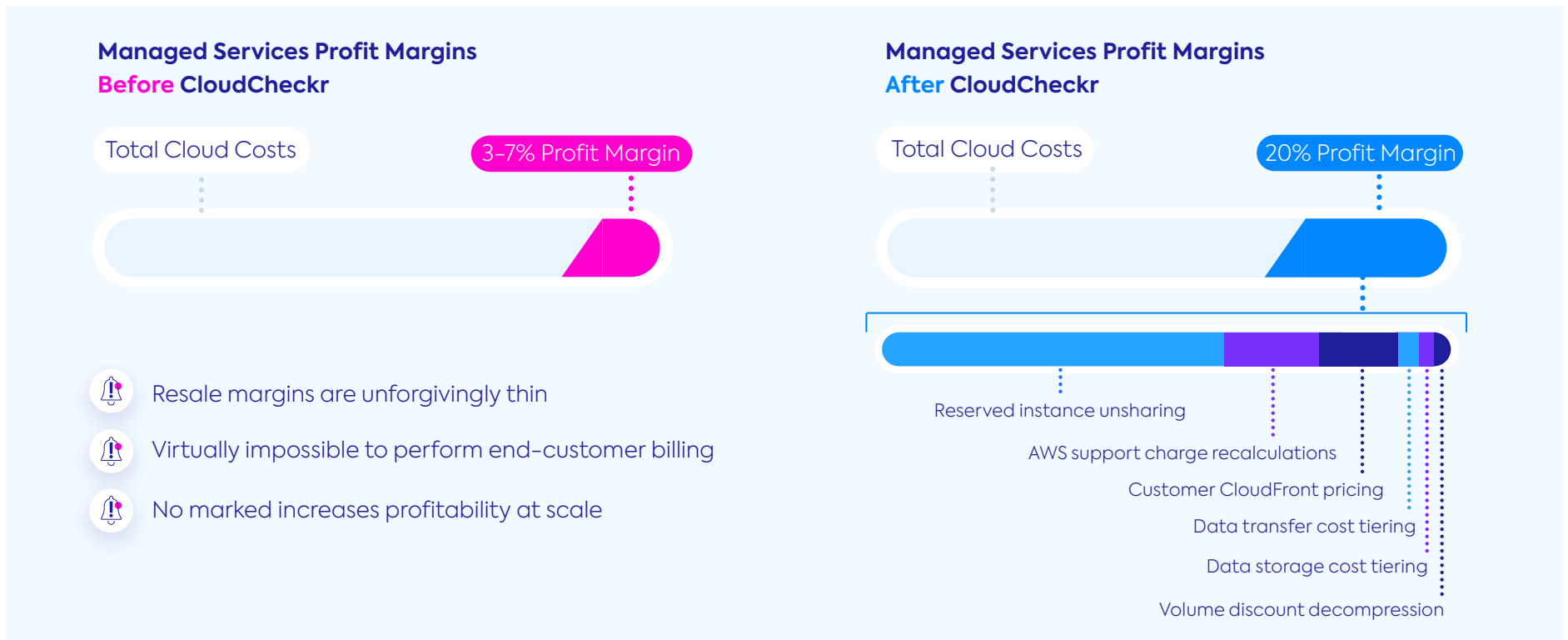

# What we value



## It's your data

We know it is your data, so we believe that customers should have options to store their data where they want, easily access what they need and share it across people and systems.

That's why we offer **multi-region hosting** options and a robust set of API tools and documentation.



## Success is shared

Optimizing your cloud can't be accomplished with software alone – it takes strategy and know-how.

That's why we include **premium support** in our engagements for most customers – rather than used as a mechanism to upsell or nickel-and-dime. Services like Regular Recurring Cost Optimization Consultation, RI Purchasing and Management Support are standard.



## We invest for you

Cloud is a dynamic, evolving market and we are committed to making sure you stay one step ahead with your governance.

That's why we over invest in **product development and R&D**, giving you a platform built on a modern architecture and focus on the use cases that matter to our unique customer base.



# Take the next step

## Get started with CloudCheckr

See why thousands of enterprises, public sector organizations and managed service providers rely on CloudCheckr to help manage and govern \$4 billion in annualized spend for their complex cloud environments.

[Watch a demo](#)

[Talk to a sales representative](#)



## About Spot by NetApp

---

The Spot by NetApp portfolio enables cloud operations teams to deliver scalability, performance and security for cloud infrastructure and applications — at the lowest possible cost — through continuous automation and optimization combined with deep visibility and governance. From cloud-native startups to global enterprises and managed services providers, thousands of customers rely on Spot solutions to unlock the full value of the cloud.